

# INSTALLATION

# Enerlites®

**66215/66205**

**15/20 Amp 125VAC Flanged Inlet with Front and Back Cover**

1. Use the template to drill 1-3/4" diameter hole.
2. Feed the cord through the cutout until the flanged inlet is flush with the installation surface.
3. Use a 1/8" drill bit to pre-drill the mounting holes for the screws on hard surfaces.
4. Secure the flanged to the surface using provided screws.
5. Plug in a live cord and you are ready to use or cover when not in use.

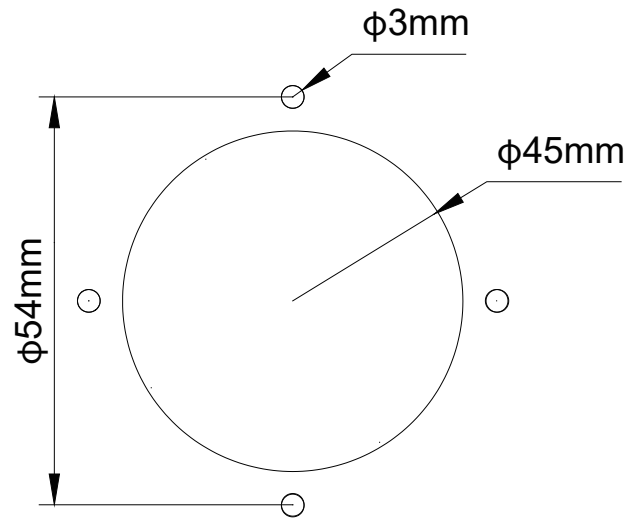
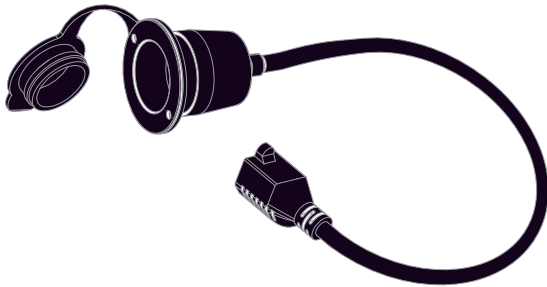

TOOLS:

- Power Drill
- 1-3/4 " Hole Saw
- #2 Screwdriver

# INSTALLATION

**66215/66205**

**15/20 Amp 125VAC Flanged Inlet with Front and Back Cover**

1. Use the template to drill 1-3/4" diameter hole.
2. Feed the cord through the cutout until the flanged inlet is flush with the installation surface.
3. Use a 1/8" drill bit to pre-drill the mounting holes for the screws on hard surfaces.
4. Secure the flanged to the surface using provided screws.
5. Plug in a live cord and you are ready to use or cover when not in use.

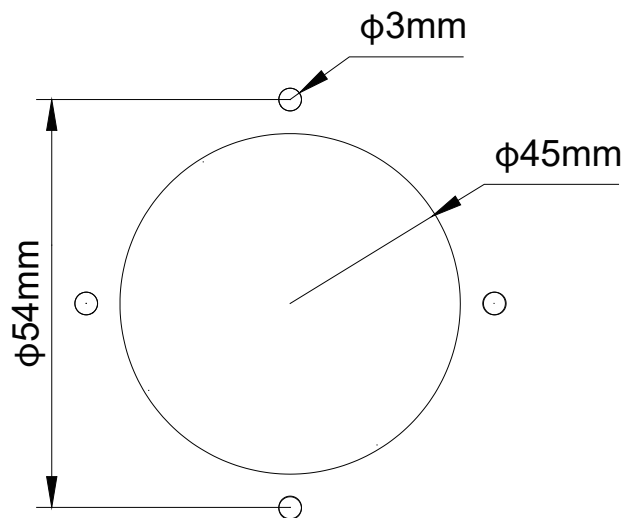
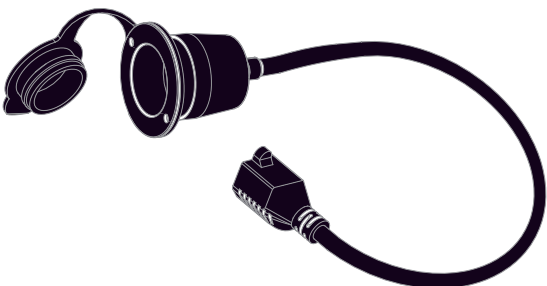

TOOLS:

- Power Drill
- 1-3/4 " Hole Saw
- #2 Screwdriver