

MODEL ENLC001AR

Adapter Ring

WARNING: Turn the **POWER OFF** at the circuit breaker before installing the adapter ring to the floor box.

Read and understand these instructions before installing. This device is intended for installation in accordance with the National Electric Code and local regulations. It is recommended that a qualified electrician performs this installation.

Use copper wires only.

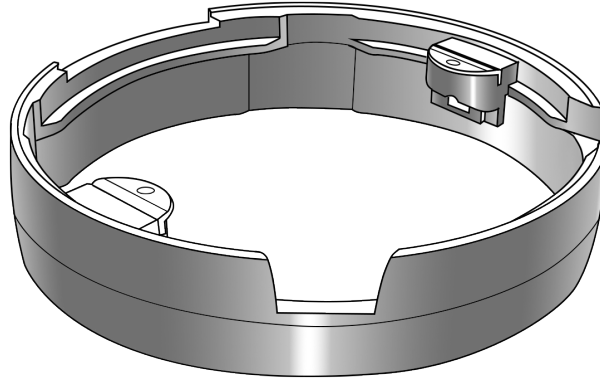

Adapter ring compatible with Enerlites part number:

- 961501-C, 961501-C-USB, 961501-C-GFCI
- 961501-S, 961501-S-USB, 961501-S-GFCI

Required:

- ENLC001 6" Non-Metallic PVC Box

WARRANTY INFORMATION

This device is warranted to be free of material and workmanship defects for 2 years from the date of purchase. Original receipt or proof of purchase from an authorized retailer must be presented upon warranty claim. ALL claims must be verified and approved by Enerlites, Inc. Warranties from other Enerlites products may vary. This warranty is nontransferable and does not cover normal wear and tear or any malfunction, failure, or defect resulting from misuse, abuse, neglect, alteration, modification, or improper installation. To the fullest extent permitted by the applicable state law, Enerlites shall not be liable to the purchaser or end user customer of Enerlites products for direct, indirect, incidental, or consequential damages even if Enerlites has been advised of the possibility of such damages. Enerlites' total liability under this or any other warranty, express or implied, is limited to repair, replacement or refund. Repair, replacement or refund are the sole and exclusive remedies for breach of warranty or any other legal theory.

© 2021 Enerlites Inc. CA, U.S.A.
WWW.ENERLITES.COM
0204170089-01
REV 20230802

MODEL ENLC001AR

Adapter Ring

WARNING: Turn the **POWER OFF** at the circuit breaker before installing the adapter ring to the floor box.

Read and understand these instructions before installing. This device is intended for installation in accordance with the National Electric Code and local regulations. It is recommended that a qualified electrician performs this installation.

Use copper wires only.

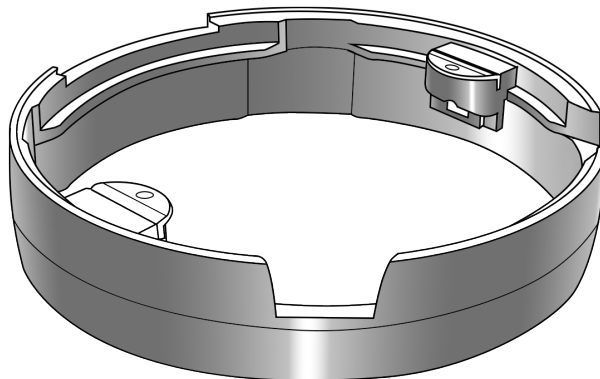

Adapter ring compatible with Enerlites part number:

- 961501-C, 961501-C-USB, 961501-C-GFCI
- 961501-S, 961501-S-USB, 961501-S-GFCI

Required:

- ENLC001 6" Non-Metallic PVC Box

WARRANTY INFORMATION

This device is warranted to be free of material and workmanship defects for 2 years from the date of purchase. Original receipt or proof of purchase from an authorized retailer must be presented upon warranty claim. ALL claims must be verified and approved by Enerlites, Inc. Warranties from other Enerlites products may vary. This warranty is nontransferable and does not cover normal wear and tear or any malfunction, failure, or defect resulting from misuse, abuse, neglect, alteration, modification, or improper installation. To the fullest extent permitted by the applicable state law, Enerlites shall not be liable to the purchaser or end user customer of Enerlites products for direct, indirect, incidental, or consequential damages even if Enerlites has been advised of the possibility of such damages. Enerlites' total liability under this or any other warranty, express or implied, is limited to repair, replacement or refund. Repair, replacement or refund are the sole and exclusive remedies for breach of warranty or any other legal theory.

© 2021 Enerlites Inc. CA, U.S.A.
WWW.ENERLITES.COM
0204170089-01
REV 20230802