

LVD-101

Low Voltage Dimmer Switch

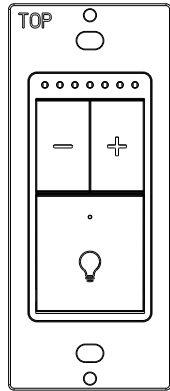

BUTTONS AND INDICATORS

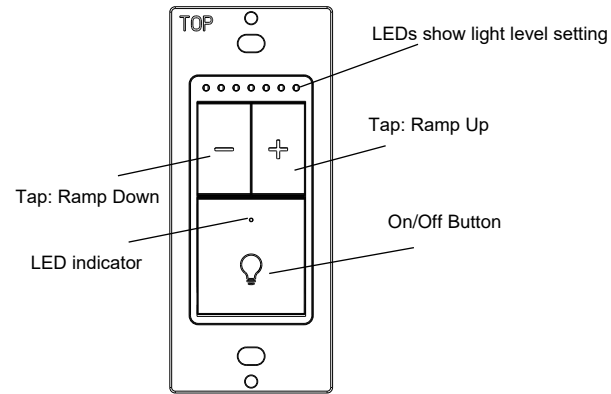

When all loads bound to the dimmer are OFF, The Blue load LED is ON.

When any load bound to the dimmer is ON the load status LED is OFF. The number of illuminated light level LEDs indicates the light level of those loads

SPECIFICATIONS

Voltage	24VDC
Current Consumption	20mA
Power Supply	Enerlites Room Controller MPP-24
Connection.....	RJ-45 Port

DESCRIPTION

LVD-101 is a low voltage LED dimmer switch, used to control various 0-10V dimmable LED panels lights and it can adjust the brightness of LED bulbs and have an LED indicator on/off button. The LVD-101 operate on 24V supplied by the MPP-24 Power Pack. They also work with the MPC-50L Low Voltage Occupancy Sensor and MPL-010 Daylight Sensor, to recognize and react to motion sensing and automatic brightness adjustments of LED lights.
The LVD-101 have several wiring options. Choose according to your requirements.
Please note: When this LVD is connected, it must be used with LV-CAT5.

LVD-101 / MPP-24

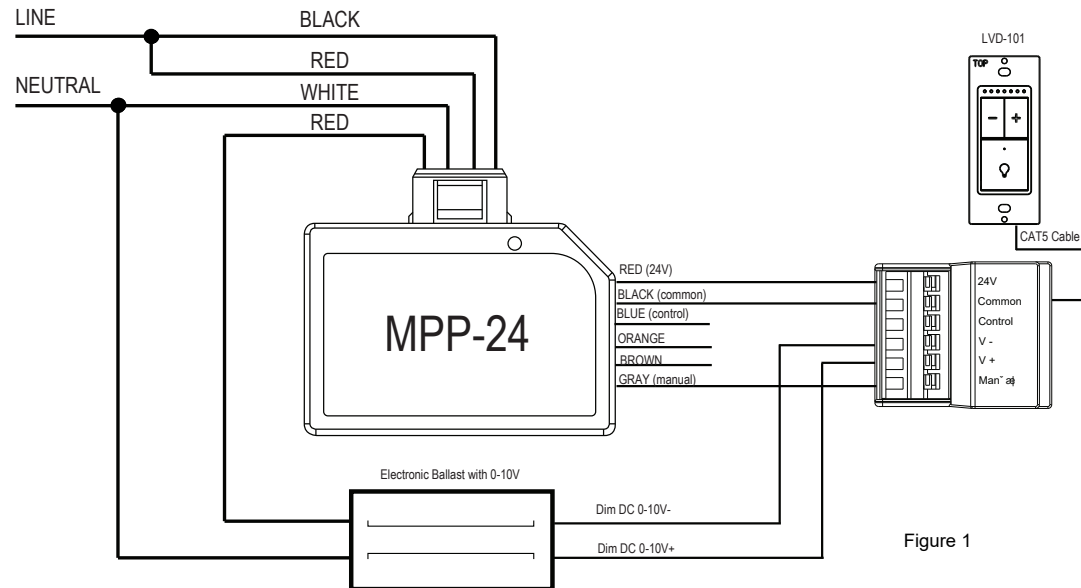
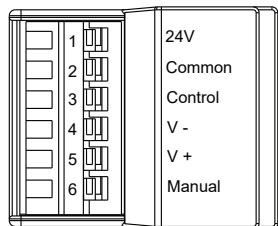

Figure 1

LV-CAT5



Optional Cat5 Individual Wires

- 24V: Orange Stripe
- Com: Orange Solid
- Control: Green Stripe
- V(-): Orange Solid
- V(+): Brown Stripe
- Man: Brown Solid

LVD-101 / MPP-24 / MPC-50L / MPL-010 Occupancy

There is a single zone with dimming and a daylight sensor. Additionally, the sensor can operate in occupancy mode.

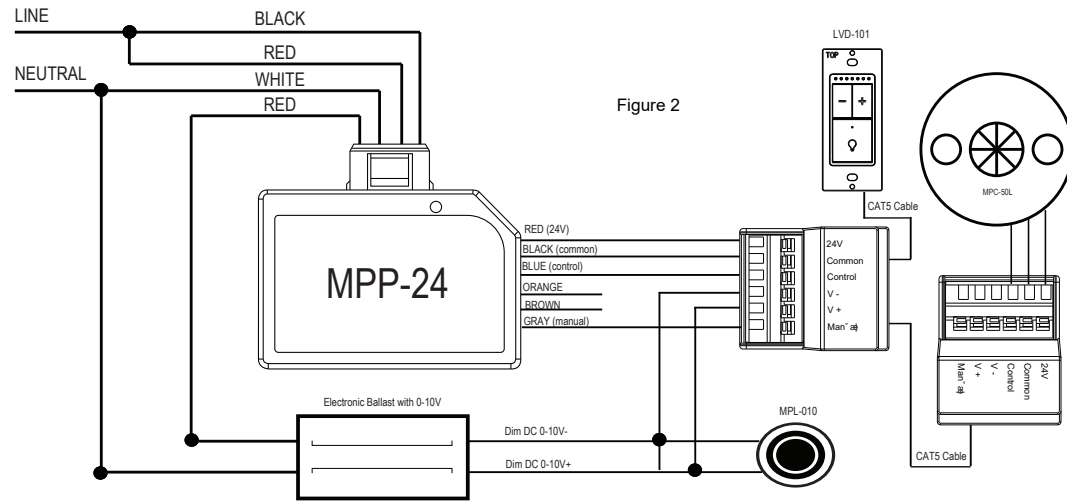

LVD-101 / MPP-24 / MPC-50L / MPL-010 Vacancy

There is a single zone with dimming and a daylight sensor. Additionally, the sensor can operate in vacancy mode.

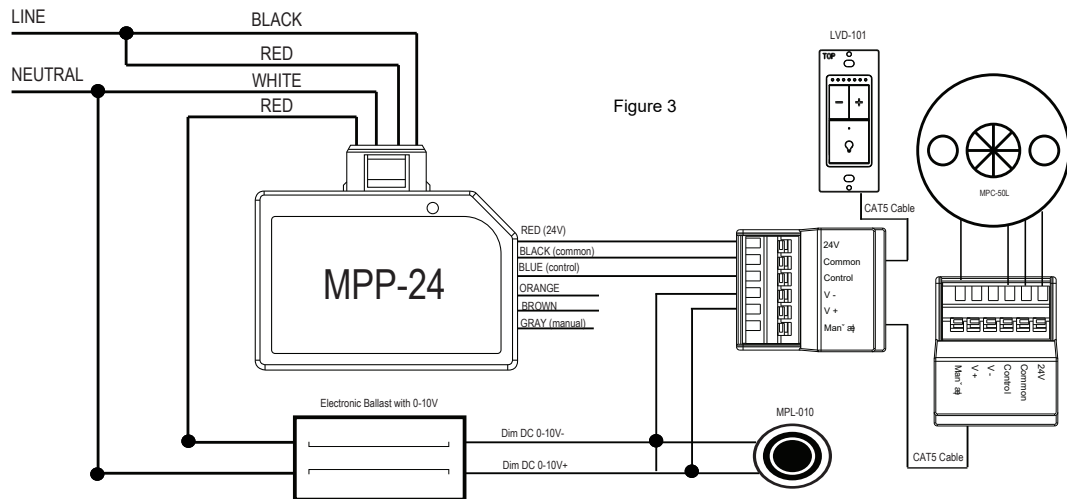

LVD-101 / MPP-24 / MPC-50L / LVS-101 Occupancy mode and 3-way

There is a single zone with dimming and a daylight sensor.

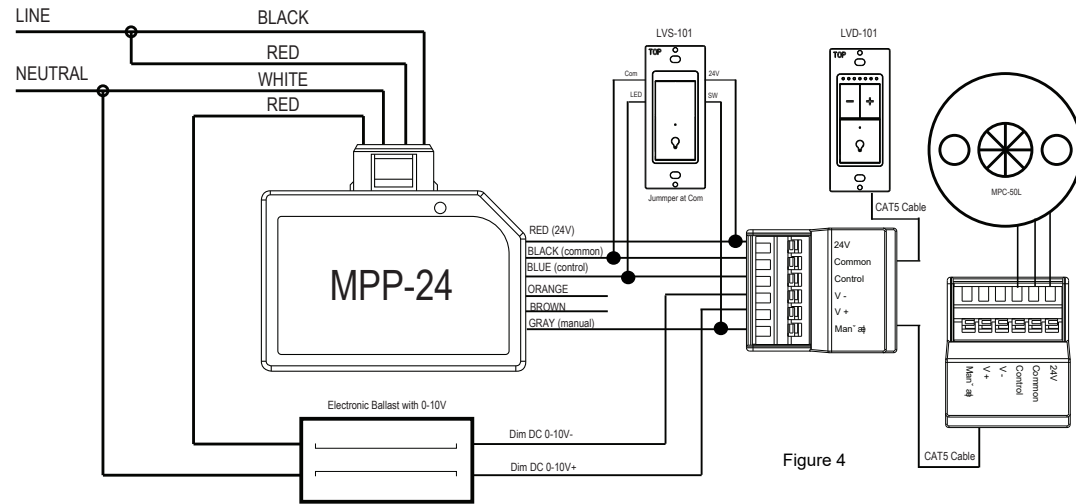

LVD-101 / MPP-24 / MPC-50L / LVS-101 Vacancy mode and 3-way

Manual On required

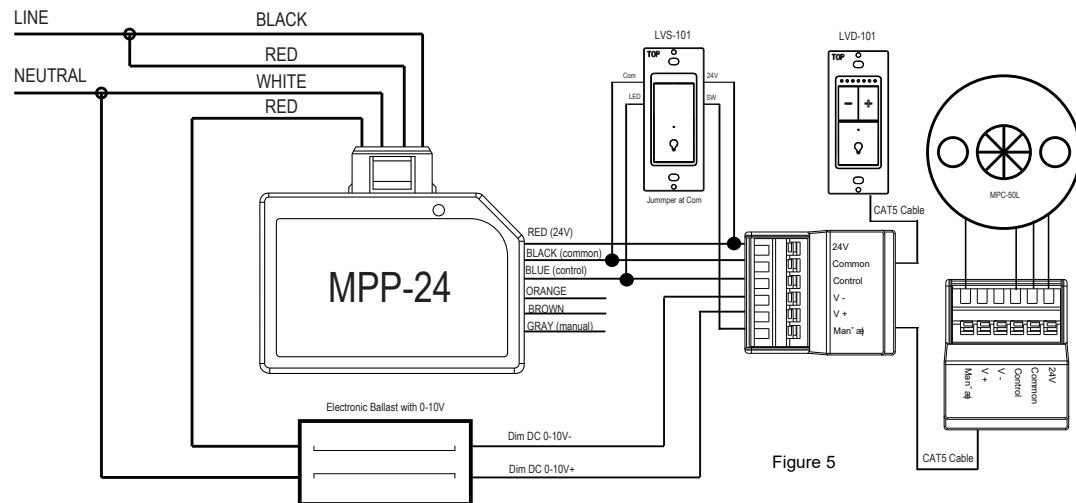

LVD-101 (2X) / MPP-24 (2X) / MPC-50L

There are two separate zones with dimming. An occupancy sensor controls both zones.

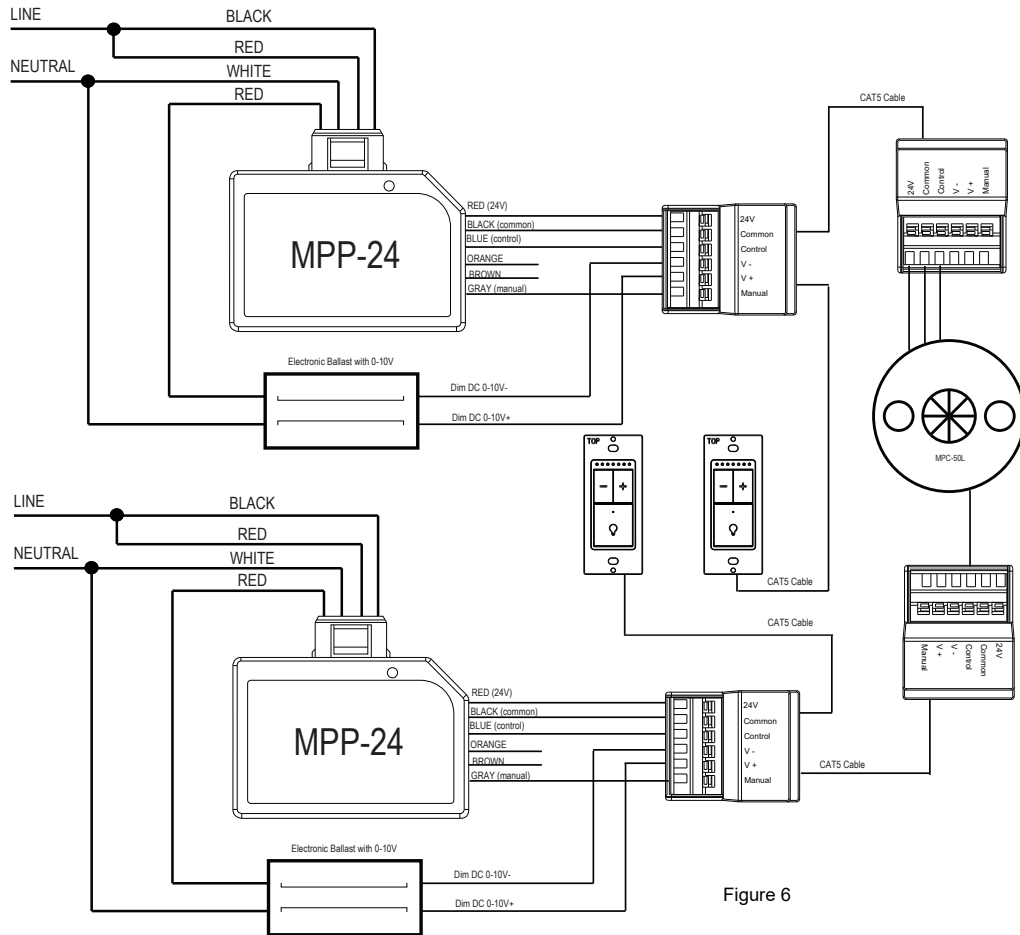

Figure 6

LVD-101 (2X) / MPP-24 (2X) / MPC-50L / MPL-010 (2x)

There are two separate zones with dimming and daylight sensors. The daylight harvesting sensor takes precedence over the dimmer during daylight hours. Additionally, an occupancy sensor controls both zones.

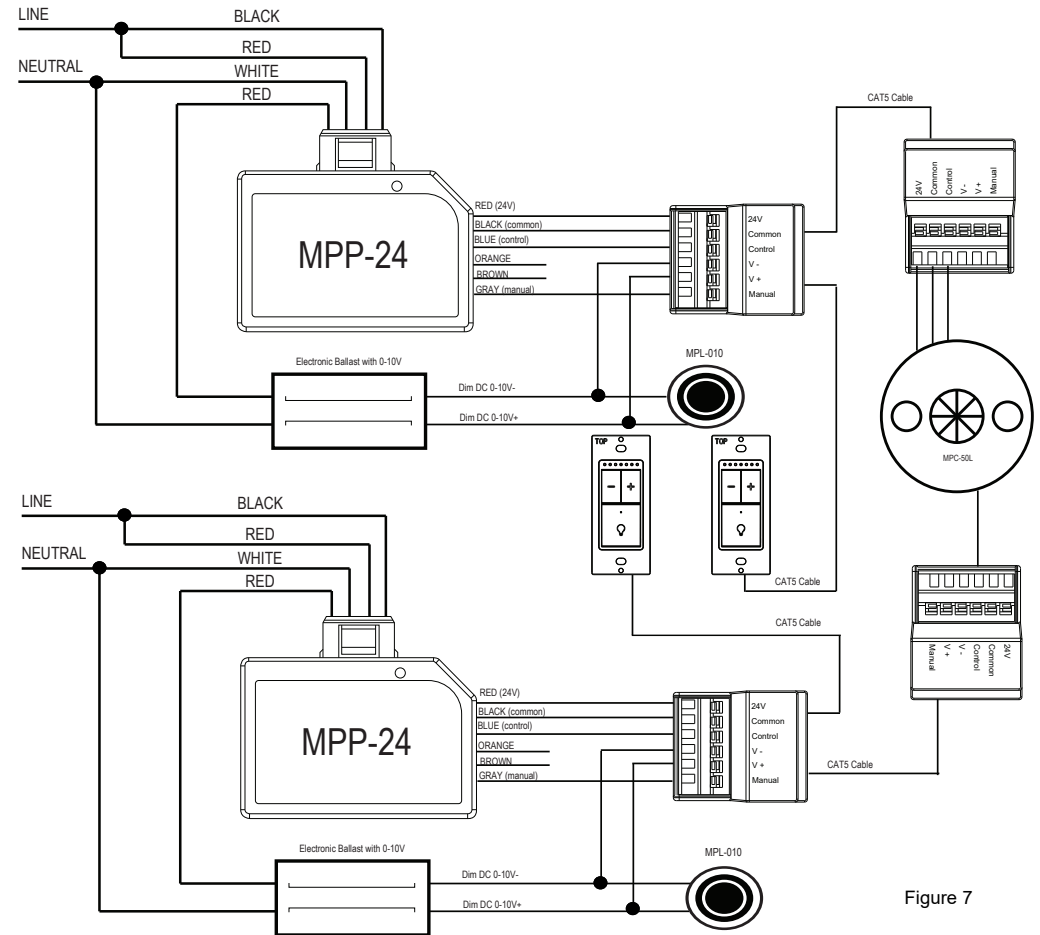

Figure 7

Occupancy Mode

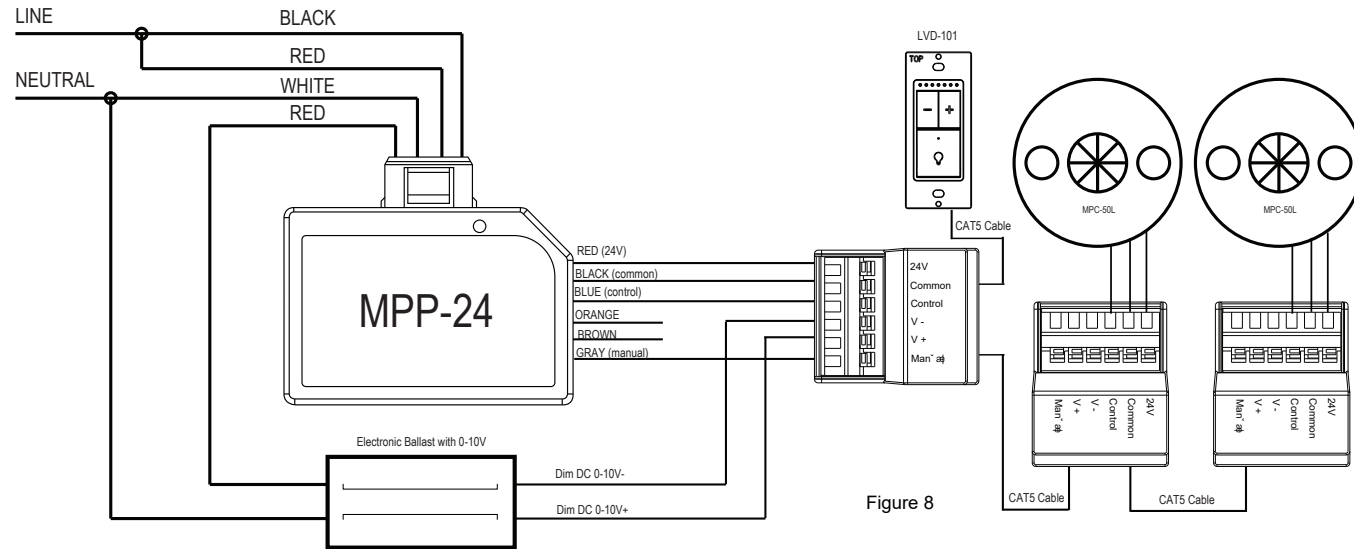

Figure 8

Vacancy Mode

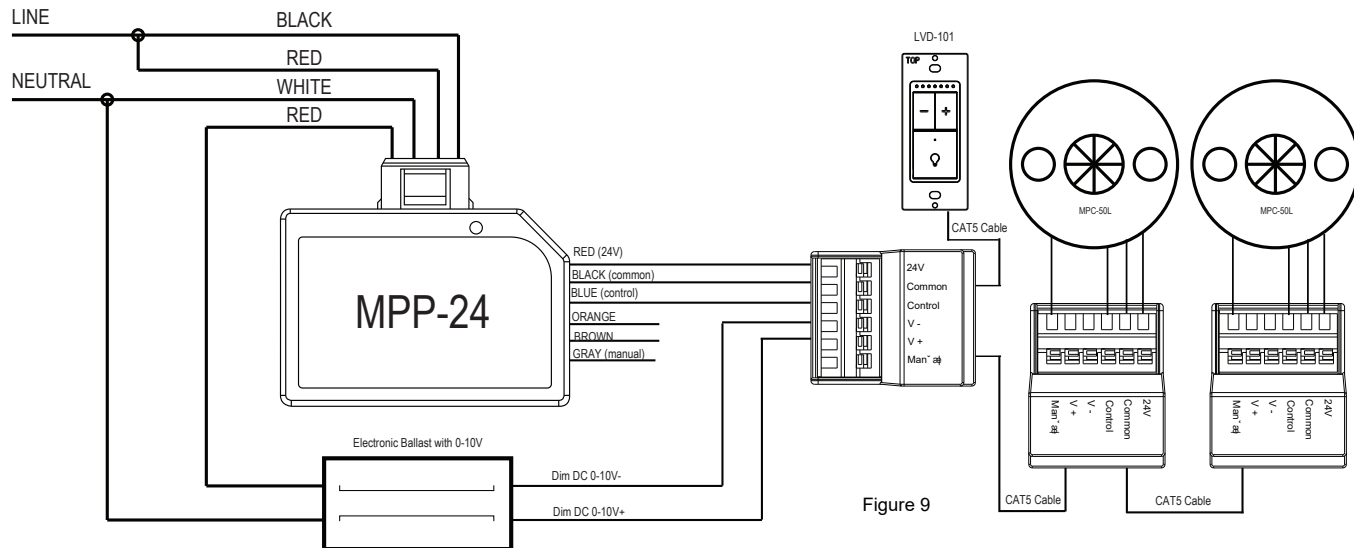

Figure 9

TROUBLESHOOTING

Load does not turn On. Sensor's LED does not flash regardless of motion:

1. Manual switch was activated prior to the sensor preset time delay. Push Manual On/Off Button to turn On the load.
2. Select the Occupancy position if "Auto ON" is what's desired.
3. Check connectivity for Red, Black, Blue and Gray wire to the LV-Cat5

The Load does not turn On when LED indicator flashes and motion is detected:

1. Switch may be in Vacancy mode. Select the OCC position if "Auto ON" is what's desired.
2. Push Manual On/Off Button to turn On the load

The Load does not turn Off:

1. Motion may be detected. The time delay constantly restarts its countdown after the last motion detected.
2. To verify proper operation, turn the Time Delay Knob to 15s (Test Mode) and make sure there is no motion (no LED flashing). Tape may be used to cover the fresnel lens while testing.
3. Check for significant heat source emitting within six feet (two meters) such as high wattage light bulb, portable heaters or HVAC vents. Check the wiring.

The Load turns on when its not desired:

1. Motion may be detected. The time delay constantly restarts its countdown after the last motion detected. To verify proper operation, set the Time Delay switches to 15s (Test Mode) and make sure there is no motion (no LED flashing). Tape may be used to cover the fresnel lens and ultrasonic cones while testing.
2. Check for significant heat source emitting within six feet (two meters) such as high wattage light bulb, portable heaters or HVAC vents.
3. If Manual operation of push-button is desired, select VAC mode on the Mode Switch.
4. If the sensor is installed in a small room, turn the Range dial lower to avoid false or unwanted detection from open window or door.

Loads constantly flashing:

1. If more than one 0-10V electronic ballasts, check 0-10V (+) and (-) from source to the LV-Cat5.

WARRANTY INFORMATION

This device is warranted to be free of material and workmanship defects for 2 years from the date of purchase. Original receipt or proof of purchase from an authorized retailer must be presented upon warranty claim. ALL claims must be verified and approved by Enerlites, Inc. Warranties from other Enerlites products may vary. This warranty is nontransferable and does not cover normal wear and tear or any malfunction, failure, or defect resulting from misuse, abuse, neglect, alteration, modification, or improper installation. To the fullest extent permitted by the applicable state law, Enerlites shall not be liable to the purchaser or end user customer of Enerlites products for direct, indirect, incidental, or consequential damages even if Enerlites has been advised of the possibility of such damages. Enerlites' total liability under this or any other warranty, express or implied, is limited to repair, replacement or refund. Repair, replacement or refund are the sole and exclusive remedies for breach of warranty or any other legal theory.