

INSTALLING Z-WAVE RECEPTACLES

INSTALLATION INSTRUCTIONS

DESCRIPTION

The **ZW15R-N** is a technologically advanced Tamper Resistant Duplex Receptacle. The top receptacle is "always ON" and the bottom receptacle is Z-Wave controlled. For the advanced users, the functions are programmable for setting scenes, associations and scheduling events.

FEATURES

- Replaces standard 120VAC receptacles
- Wireless Z-Wave technology creates a mesh network for command and control interoperability with other Z-Wave compliant controllers and devices
- Manual and remote on/off control of any connected load
- Tamper-resistant (TR) receptacles keep you and your family safe
- Reduce energy consumption and enjoy wireless home automation
- Over Current and Short Circuit protection up to 15A

REQUIREMENTS

Z-Wave devices requires a connection to a compatible hub. Once the device is properly added to the Hub, it can be managed and customized to your needs. Please visit www.enerwaveautomation.com for a list of compatible hubs.

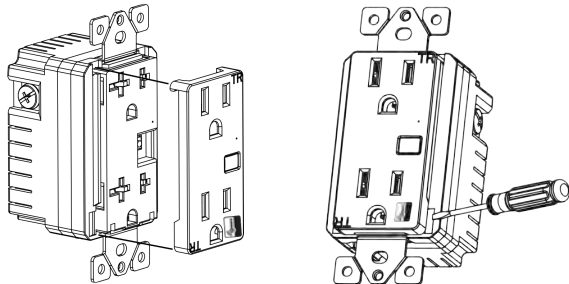

SPECIFICATIONS

Voltage.....	120VAC, 60Hz
Incandescent.....	1000W
Ballast.....	1200VA
Resistive.....	1800W(15A)
Motor.....	1/2 HP
Z-Wave Frequency.....	908.42 MHz
Operating Temperature.....	32-104° F

WARNING: Turn the POWER OFF at the circuit breaker before installing the Receptacle

Read and understand these instructions before installing. This device is intended for installation in accordance with the National Electric Code and local regulations. It is recommended that a qualified electrician performs this installation. Make sure to turn off the circuit breaker or fuse(s) and make sure power is off before wiring the device. Exercise extreme caution when using Z-Wave devices to control appliances. Operation of the Z-Wave device may be in a different room than the controlled appliance so an unintentional activation may occur if the wrong button on the remote is pressed. Z-Wave devices can be automatically powered on by programmed events. Unattended or unintentional operation could result in hazardous conditions. Z-Wave enabled devices should never be used to supply power to, control, or monitor medical and/or life support equipment. **Use copper wires only.**

Model: ZW15R-N
Wireless Home Automation Control Device
15A Tamper Resistant Duplex Receptacle
with Interchangeable Face Cover



LOCATIONS

Installation of Z-Wave devices instantly increases the functionality, efficiency, and value of your home. The more devices you install, the more efficient your house will be. The most effective locations to install Z-Wave devices are in the Living Room, Bedrooms, Kitchens, Family Rooms, Guest Rooms, and Entertainment Rooms.

This device complies with the Z-Wave standard of open-air, line of sight transmission distances of 100 feet. Actual performance in a home depends on the numbers of walls between the remote controller and the destination device, the type of construction and the number of Z-Wave enabled devices installed in the control network. Z-Wave devices act as signal repeaters ONLY after they are "Included" on the network.

Distance of the Z-Wave Device (or repeating Z-Wave module) to CONTROLLER:					
Type of Construction	Wood Frame with Drywall		Brick, Tile or Concrete		
	Plastic J-Boxes*	Metal J-Boxes	Plastic J-Boxes*	Metal J-Boxes	
Number of Walls or Obstructions	0**	100'	80'	100'	80'
	1	70'	56'	60'	48'
	2	49'	39'	36'	29'
	3	34'	27'	21'	17'

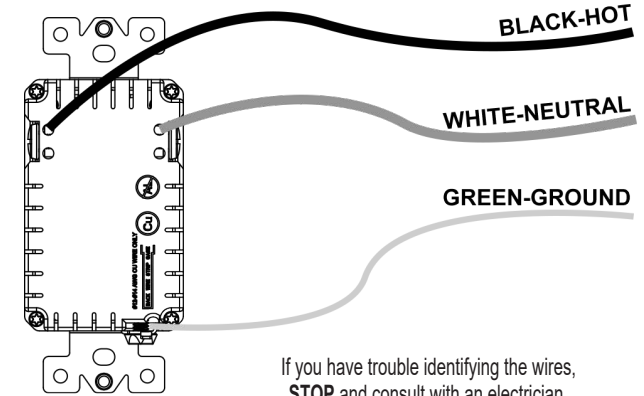

If you have trouble identifying the wires, **STOP** and consult with an electrician.

NOTES

This Z-Wave device must be configured and added to a Z-Wave network before it can be operated and controlled from a smart device. Follow the instructions on the next page and the manual(s) associated with the Hub for configuration.

DO NOT REVERSE ANY WIRES. DOING SO WILL VOID YOUR WARRANTY AND THE RECEPTACLE WILL SHORT CIRCUIT.

Step 1. Identify all your wires. Label the wires or draw a diagram of existing wires.

Step 2. Insert wires into the terminal holes on the back, then tighten the terminal screws.

- Connect the BLACK wire to the HOT terminal (brass screw).
Connect the WHITE wire to the NEUTRAL terminal (silver screw).
- Connect the GREEN or BARE wire to the GROUND terminal (green screw).

FCC COMPLIANCE STATEMENT

FCC Grant of Equipment Authorizations of this device and transmitters installed in this device can be found at FCC website by entering the FCC ID number on the device.

Caution: Changes or modifications not expressly approved by the part responsible for compliance could void the user's right to operate the equipment.

This device complies with Part 15 of the FCC Rules. Operation is subject to the following two conditions: (1) this device may not cause harmful interference, and (2) this device must accept any interference received, including interference that may cause undesired operation of the device.

This equipment has been tested and found to comply with the limits for a Class B digital device, pursuant to part 15 of the FCC rules. These limits are designed to provide reasonable protection against harmful interference in a residential installation. This equipment generates, uses and can radiate radio frequency energy and, if not installed and used in accordance with the instructions, may cause harmful interference to radio communications. However, there is no guarantee that interference will not occur in a particular installation. If this equipment does cause harmful interference to radio or television reception, which can be determined by turning the equipment off and on, the user is encouraged to try to correct the interference by one or more of the following measures:

- Reorient or relocate the receiving antenna.
- Increase the separation between the equipment and receiver.
- Connect the equipment into an outlet on a circuit different from that to which the receiver is connected.
- Consult the dealer or an experienced radio/TV technician for help.

WARRANTY INFORMATION

This device is warranted to be free of material and workmanship defects for 2 years from the date of purchase. Original receipt or proof of purchase from an authorized retailer must be presented upon warranty claim. ALL claims must be verified and approved by Enerwave, Inc. Warranties from other Enerwave products may vary. This warranty is nontransferable and does not cover normal wear and tear or any malfunction, failure, or defect resulting from misuse, abuse, neglect, alteration, modification, or improper installation. To the fullest extent permitted by the applicable state law, Enerwave shall not be liable to the purchaser or end user customer of Enerwave products for direct, indirect, incidental, or consequential damages even if Enerwave has been advised of the possibility of such damages. Enerwave' total liability under this or any other warranty, express or implied, is limited to repair, replacement or refund. Repair, replacement or refund are the sole and exclusive remedies for breach of warranty or any other legal theory.

Enerlites®

© 2016 Enerwave Home Automation
 CA, USA
WWW.ENERLITES.COM
 0209160046-03

PROGRAMMING

DEVICE INCLUSION/ EXCLUSION

The process of "Inclusion/ Exclusion" is to Add or Remove the device from the Hub. All Z-Wave devices must be "Included" on the Controller (Hub) before it can be controlled from a smart device. The Hub should be brought physically closer to the device just for the "Inclusion" process (**recommended within 10ft**). When finished, the Hub and device can be moved back to final installation location. Download the App or log onto the website associated with the Hub you are using and follow their Inclusion/ Exclusion instructions as each Hub's programming and features are different.

- During the Inclusion/ Exclusion process, the manual ON/OFF button is used for including/ excluding the device.
- It is best to perform an Exclusion of the device prior to performing an Inclusion.

- Step 1.** From the Control Panel, go to the device Exclusion page.
- o Select "Exclude Device".
 - o When prompted, press and hold the manual ON/OFF Button on the receptacle 3 seconds.
- Step 2.** Go to the "Add Device" page.
- o Select "Include Device".
 - o When prompted, press and hold the manual ON/OFF Button on the receptacle 3 seconds.

The primary controller should indicate that the action was successful. If the controller indicates the action was unsuccessful, please repeat from Step 1. Once the receptacle is part of the network, the same basic procedure is used to add the switch to groups & scenes or change advanced functions. Refer to the primary controller's instructions for details.

- Step 3.** Follow the On-Screen instructions in the Control Panel on adding or removing rooms, scenes, other devices, and other functions and features.
- Step 4.** To reset the ZW15R-N manually, simply press and hold the ON/OFF button for 10 seconds.

OPERATING THE ZW15R-N

You're now ready for basic operation of the ZW15R-N. The manual button turns the controlled receptacle (bottom) ON/OFF when the button is pressed once. It can also be operated from your desktop on the control panel provided on the Hub manufacturer's website or a smart device such as the iPhone, iPad or any Android device once the appropriate App is installed on the device.

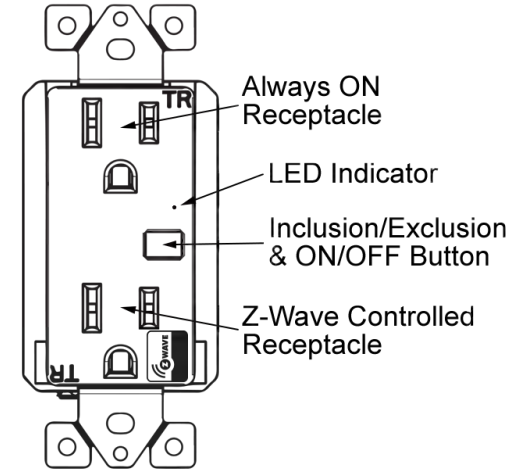

ADVANCED PROGRAMMING

WARNING: Advanced programming is recommended ONLY for experienced programmers. The ZW15R-N has customizable features / functions that require writing codes. Changes to code may cause device to function improperly or to not function at all.

The following parameters require that you have an advanced controller. Basic remotes do not have this capability.

All-ON and All-OFF

Depending upon your primary controller, the ZW15R-N can be set to respond to ALL-ON and ALL-OFF commands in four different ways. Some controllers may not be able to change the response from its default setting. Please refer to your controller's instructions or technical support for information on whether or not it supports the configuration function and if so, how to change this setting. **The four possible responses for the manual ON/OFF button are:**

- Push button will respond to ALL-ON and the ALL-OFF command (default).
- Push button will not respond to ALL-ON or ALL-OFF commands.
- Push button will respond to the ALL-OFF command but will not respond to the ALL-ON command.
- Push button will respond to the ALL-ON command but will not respond to the ALL-OFF command.

LED Light and Buttons Configuration

By default, one press of the manual button will turn the Load on and the LED indicator will turn off. Use "Command_Class_Configuration" to configure the LED indicator to operate in reverse when the button is pressed.

Configuration details

- Parameter 1 (configure LED light state), default value is 0. Valid values are 0 and 1 with 1 byte.
- Parameter 2 (configure button toggle), default value is 0. Valid values are 0 and 1 with 1 byte.

OTHER RECOMMENDED Z-WAVE PRODUCTS

Innovative devices by Enerwave such as the ZW15R-N have made their way to homes all across America and have simplified home automation. As the demand for energy efficiency has grown to new heights, so has technologically advanced devices that puts the control of energy at our fingertips. Enerwave offers the most current, customizable and controllable products. Here are a few of our devices that will expand your Z-Wave network and simplify how you monitor and control your power usage.



ZWN-323M
Plug-in Smart Meter Dimmer Module



ZWN-333
Plug-in Appliance Module

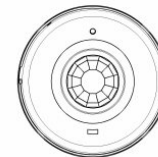

ZWN-BPC
Ceiling Mounted PIR Motion Sensor
With little setup, this motion sensor can be used to turn on any programmed Z-Wave device when motion is detected

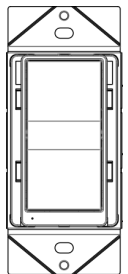

ZW15S-N
ON/OFF Switch

ZW15R-N